

Analog Peripherals

Two 16-Bit ADCs

- ± 0.75 LSB INL; guaranteed no missing codes
- Programmable throughput up to 1 Msps (each ADC)
- Configurable as two single-ended or one differential ADC
- DMA to XRAM or external memory interface
- Data-dependent windowed interrupt generator

10-Bit ADC

- Programmable throughput up to 200 ksps
- 8 external inputs
- Built-in temperature sensor (± 3 °C)

Two 12-Bit DACs

- Can synchronize outputs to timers for jitter-free waveform generation

Three Comparators

Internal Voltage Reference

Precision V_{DD} Monitor/Brown-out Detector

On-Chip JTAG Debug & Boundary Scan

- On-chip debug circuitry facilitates full speed, non-intrusive in-system debug (no emulator required)
- Provides breakpoints, single stepping, watchpoints, stack monitor
- Inspect/modify memory and registers
- Superior performance to emulation systems using ICE-chips, target pods, and sockets
- IEEE1149.1 compliant boundary scan

Supply Voltage: 2.7 to 3.6 V

- Typical operating current: 10 mA at 25 MHz
- Multiple power saving sleep and shutdown modes

High-Speed 8051 μ C Core

- Pipelined instruction architecture; executes 70% of instructions in 1 or 2 system clocks
- Up to 25 MIPS throughput with 25 MHz system clock
- Expanded interrupt handler

Memory

- 4352 bytes data RAM
- 64 kB Flash; in-system programmable in 1024-byte sectors (1024 bytes are reserved)
- External parallel data memory interface

CAN Bus 2.0B

- 32 message objects
- "Mailbox" implementation only interrupts CPU when needed

Digital Peripherals

- 59 port I/O; all are 5 V tolerant
- Hardware SMBus™ (I2C™ compatible), SPI™, and two UART serial ports available concurrently
- Programmable 16-bit counter array with 6 capture/compare modules
- 5 general-purpose 16-bit counter/timers
- Dedicated watchdog timer; bidirectional reset
- Real-time clock mode using timers or PCA

Clock Sources

- Internal programmable 2% oscillator: up to 24.5 MHz
- External oscillator: Crystal, RC, C, or Clock

100-Pin TQFP

- Temperature Range: -40 to $+85$ °C

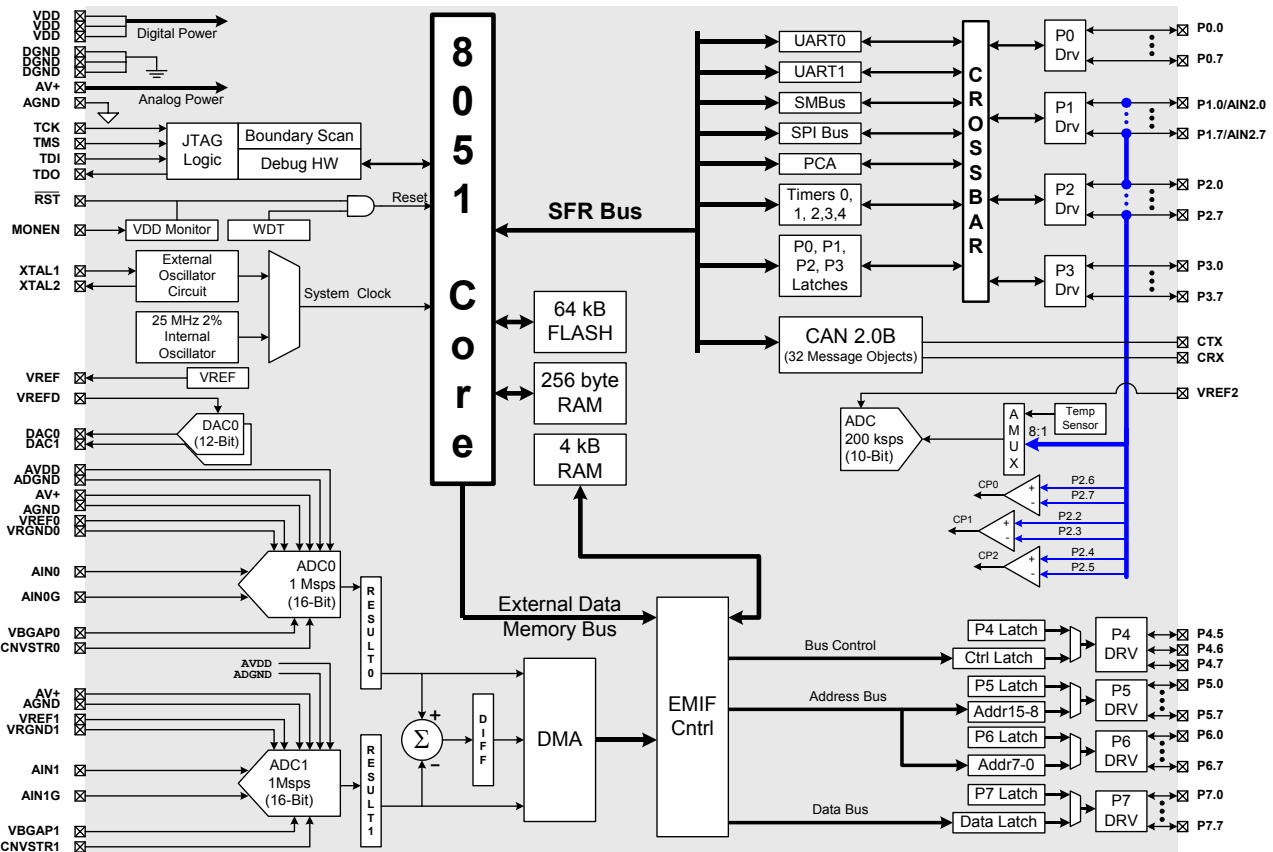

Selected Electrical Specifications

($T_A = -40$ to $+85$ °C, $V_{DD} = 2.7$ V unless otherwise specified)

PARAMETER	CONDITIONS	MIN	TYP	MAX	UNITS
GLOBAL CHARACTERISTICS					
Supply Voltage		2.7		3.6	V
Supply Current (CPU active)	Clock = 25 MHz		18		mA
	Clock = 1 MHz		0.7		mA
	Clock = 32 kHz; V_{DD} Monitor Enabled		20		μ A
Supply Current (shutdown)	Oscillator not running; V_{DD} Monitor Disabled		0.1		μ A
Clock Frequency Range		DC		25	MHz
16-BIT A/D CONVERTERS					
Resolution			16		bits
Integral Nonlinearity	Single-ended Mode		± 0.75	± 2	LSB
	Differential Mode		± 0.50	± 1	LSB
Differential Nonlinearity	Guaranteed Monotonic		± 0.5	± 1	LSB
Signal-to-Noise Plus Distortion	$F_{in} = 10$ kHz, Single-ended		86		dB
	$F_{in} = 10$ kHz, Differential		89		dB
Total Harmonic Distortion	$F_{in} = 10$ kHz, Single-ended		96		dB
	$F_{in} = 10$ kHz, Differential		103		dB
Spurious-Free Dynamic Range	$F_{in} = 10$ kHz, Single-ended		97		dB
	$F_{in} = 10$ kHz, Differential		104		dB
Throughput Rate				1	Msp/s
Input Voltage Range	Single-ended ($A_{INn} - A_{INnG}$)	0		V_{REF}	V
	Differential ($A_{IN0} - A_{IN1}$)	$-V_{REF}$		V_{REF}	V
Power Supply Current (each ADC)	Operating Mode, 1 Msp/s ($AV_{DD} + AV+$)		5.5		mA
	Shutdown Mode		1		μ A
D/A CONVERTERS					
Resolution			12		LSB
Differential Nonlinearity				± 1	LSB
Output Settling Time			10		μ s

Package Information

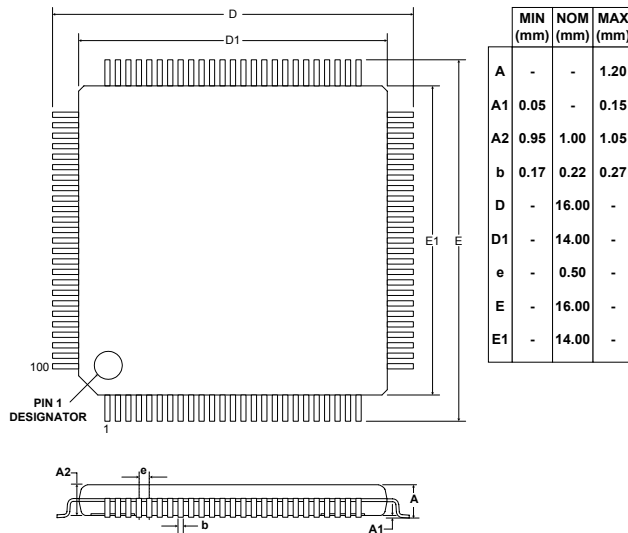

C8051F060DK Development Kit

